

Universal Cleaner U 12 2.4 / U 15 2.4



The PETKUS Universal Cleaner U 12 and U 15 are combined multi-purpose air screen cleaning machines of a new and modern machine concept, suitable for the pre-, intensive and final seed cleaning of cereals, corn, beans etc., and fine seeds to the highest standard of quality.

The various screen layers in the Universal Cleaner can be utilized according to requirements to meet the actual cleaning process either for scalping, grading, sorting or sifting.

Equipment:

Intake system:

The Multi Cleaner is provided with intake buffer bin and a feeding roller combined with a weight balanced intake flap. The weight rollers on both sides of the flap allowing the adjustment of the feed of the product.

The pre-suction system, which removes up the dust and lightweight trash before screening, is equipped with a separate expansion chamber supplied with extraction auger and a fingerflap seal system by the outlet.

Upper screen shoe:

The upper screen shoe is supplied with 2 screen layers usable for various separation of waste parts from the product.

The two upper sieves remove oversize rejects from the product.

PETKUS seed flow control system:

The first upper screen can be equipped with a special PETKUS sieve cleaning system. The PETKUS universal sieve cleaning system of the first upper sieve is based on the combination of endless moving chains with blades and rubber balls. This system keeps both the screen perforations clear of lodging particles, and controls the rate of movement of the product along the screen surface - called: PETKUS seed flow control system. The special effect of the PETKUS seed flow control system is a smaller overall-area compared to conventional cleaners.

(The seed flow control system can be delivered as an option.)

Lower screen shoe:

The lower screen shoe is supplied with 2 screen layers, which can be utilized according to requirements by using the multiflow screen diagram. All screen segments are interchangeable and mounted in a double size screen frame of aluminium, and a frame for antifreezing rubber balls which are keeping the screen surface clean.

The angle of the screens are adjustable (option).

Drive of the machine:

The drive unit includes the main eccentric system, which guarantees a perfect balance and a vibration free motion with motor console and V-belt drive.

The frequency of the screen shoes are adjustable by frequency converter (option).

Main suction system:

The main-suction system is independent from the pre-suction system and incorporates the leak-air principle for easy adjustment of the air volume and velocity. Furthermore completed with separate expansion chamber mounted with extraction auger supplied with a fingerflap seal-system by the outlet. The suction system is prepared for connection to a separate fan or a central aspiration system.

- Seed cleaning capacity: 10 / 15 t/h based on wheat
- Screen width: U 12 / U 15 = 1200 / 1500 mm
- No. Of Upper Screens: 2 Layer each with 2 changeable sieves
- No. Of Lower Screens: 2 Layer each with 2 changeable sieves
- Screen area, total: 6,72 m² / 8,40 m²

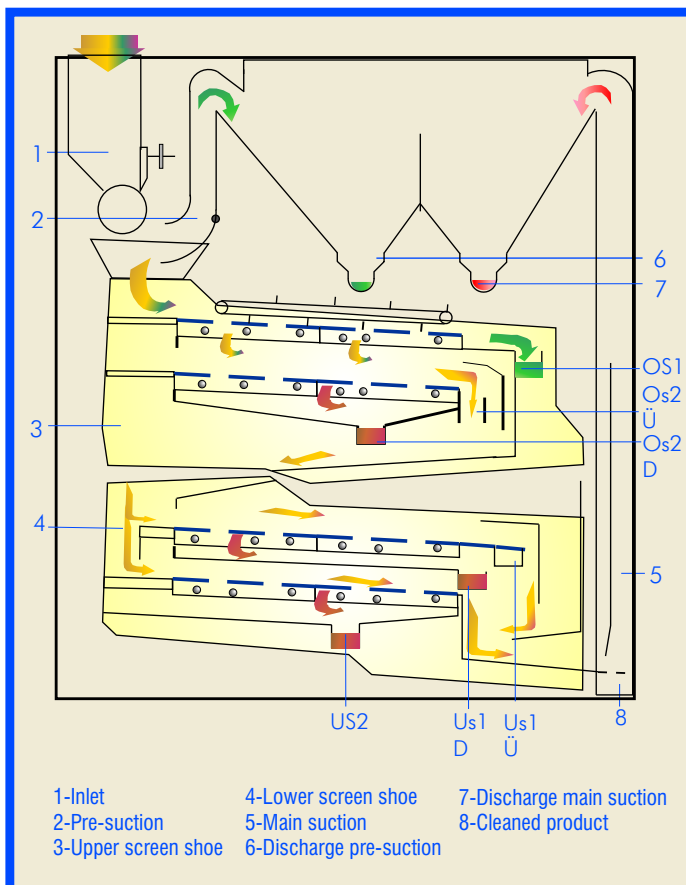

Universal Cleaner U 12 2.4 / U 15 2.4

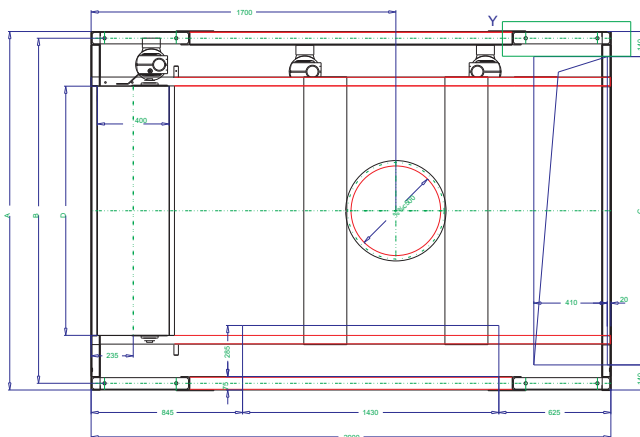
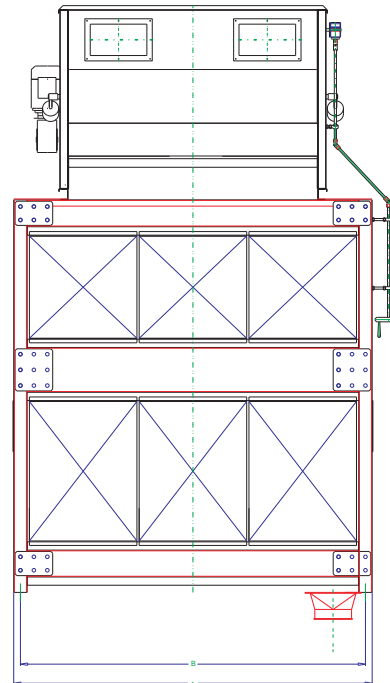
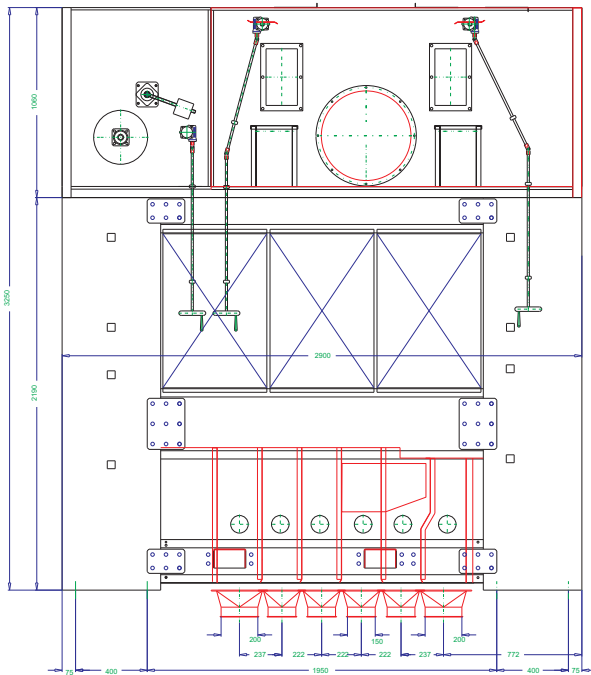

Einzelheit Y

Detail Y

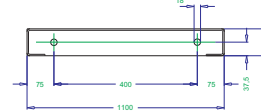

Drehfrequenz: $n = 300 \text{ min}^{-1} = 5,0 \text{ s}^{-1}$
 Rotary frequency: $n = 300 \text{ min}^{-1} = 5,0 \text{ s}^{-1}$

	Gewicht (kg) Weight (kg)	Lasten pro Fuß (kN) Load per foot (kN)	
		F_H	F_V
U12 2.4	3000	$\pm 0,9$	$7,5 \pm 1,5$
U15 2.4	3200	$\pm 1,2$	$8,0 \pm 1,9$

Technical Data		U 12 2.4	U 15 2.4
Capacity (wheat)			
Pre-cleaning	t/h	80	100
Seed cleaning	t/h	10	15
Intensive cleaning	t/h	20	25
Fan	kW	11,0-15,0	15,0-18,0
Air volume (wheat)	m ³ /h	9.000	12.000
Working width	mm	1.200	1.500
Screen area, total	m ²	6,72	8,40
Upper screen shoe			
Screen layer	Stck.	2	2
Lower screen shoe			
Screen layer	Stck.	2	2
Drive			
Screen compartment	kW	4,0	4,0
Seed flow control upper sieve	kW	0,55	
Inlet	kW	0,55	
Discharge auger	kW	0,55	

Technical Data		U 12 2.4	U 15 2.4
Dimensions			
A	mm	1700	2000
B	mm	1625	1925
C	mm	1090	1390
D	mm	1420	1720
Number of screen segments			
Upper screen layers			
Layer 1-2	Stck.	2 x 8	2 x 10
Lower screen layers			
Layer 1-2	Stck.	2 x 8	2 x 10
Total	Stck.	32	40
Frequency	Hz	5,0	5,0
Load horizontal	F_H	$\pm 0,9$	$\pm 1,2$
Load vertical	F_V	$7,5 \pm 1,5$	$8,0 \pm 1,9$
Total weight	Kg	3000	3200

Alteration reserved.